

TranTek Systems pre-engineered automation cells are cost-effective and offer the following features and benefits:

- Common bases for ease of installation and start-up
- Work cell design is adaptable to multiple configurations and applications
- Available with tooling for a turn-key single source solution
- Pre-engineered for shorter lead-times
- Low investment cost
- PLC/HMI and other features of high technical content are included
- Safety PLC is standard
- Customer selectable component options in base price
- Compatible with all robot manufacturers
- Easy tool accessibility from rear entry doors
- Obstruction-free cell access with hidden cable routing
- Preconfigured PLC/HMI base programs for easy start-ups

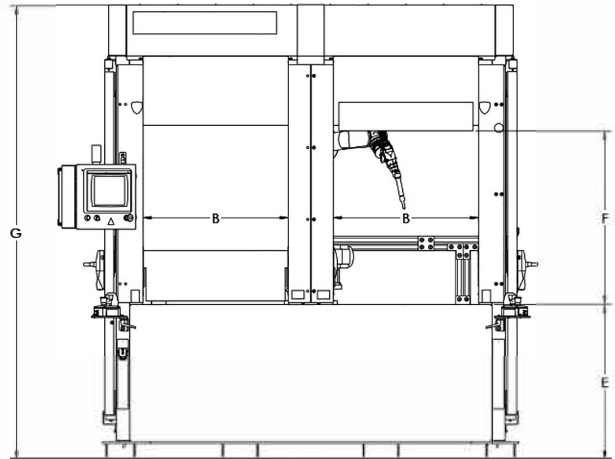
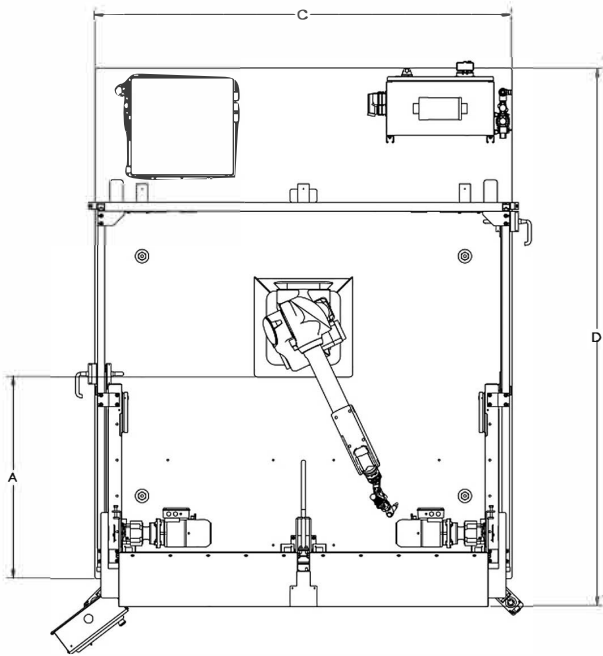

WORK CELL DIMENSIONS

| | |
|----------------------------------|--------------------|
| "A" - Work Area | 45.00" (1143mm) |
| "B" - Front Opening Width | 32.50" (825.5mm) |
| "C" - Overall Width | 93.00" (2362mm) |
| "D" - Overall Length | 120.12" (3051mm) |
| "E" - Work Height | 34.63" (880mm) |
| "F" - Opening Height | 44.00" (1117.6mm) |
| "G" - Overall Height | 101.41" (2575.8mm) |

OPTIONAL FEATURES

| | |
|------------------------|--------------------------|
| Light Hood | For vision applications |
| Tool Positioner | Robot aux axis |
| Manual Doors | Horizontal sliding doors |
| Remote Access | For off-site support |

INCLUDED FEATURES

| | |
|--|---|
| Light Curtains | 14mm resolution cascadable |
| Cell Lighting | Industrial led light bars |
| Robot Riser | 300-620mm height range (100mm increments) |
| Two Safety Gates | Solenoid locking with internal release with lock-out |
| Integrated Cell | Functionally programmed cell ready for tooling |
| Stack Light | 3 color red, amber & green |
| Operator Runbar | Cycle start OPTO-Touch & E-Stop |
| PLC (Choice Of) | AB CompactLogix Safety Processor 5069 L310ERS2 Siemens SIMATIC S7-1500 F |
| HMI (Choice Of) | AB PanelView Plus 7-10" Siemens TP1200 Comfort Panel |
| Paint Color (Choice Of) | Any RAL color pallet industrial enamel |
| Lower Panel Color | Red, blue or charcoal 1/4" polymer panel |
| Viewable Weld Windows | 1/4" clear polycarbonate panels with blue curtains |
| PLC Main Panel | Low voltage control panel (24VDC) |
| Power Distribution Panel | High voltage control panel (120VAC-480VAC) |
| Quick Disconnect Tooling Features | Ethernet I/O available at tooling |
| FRL & Drip Leg | 1/2" drip leg, filter regulator & lock-out |
| Automatic Doors | Vertical roll-up |
| Tool Riser | Tubular frame |



TRANTEK SYSTEMS
 417 HUGHES DRIVE
 TRAVERSE CITY, MI 49696
 PHONE: 231-946-6270
 FAX: 231-946-3206
 E-MAIL: INFO@TRANTEKSYSTEMS.COM
 TRANTEKSYSTEMS.COM